



Geolodge

Space & Equipment

Geolodge packages



DeLuxe Suite Lodge



Standard Lodge



Suite Lodge



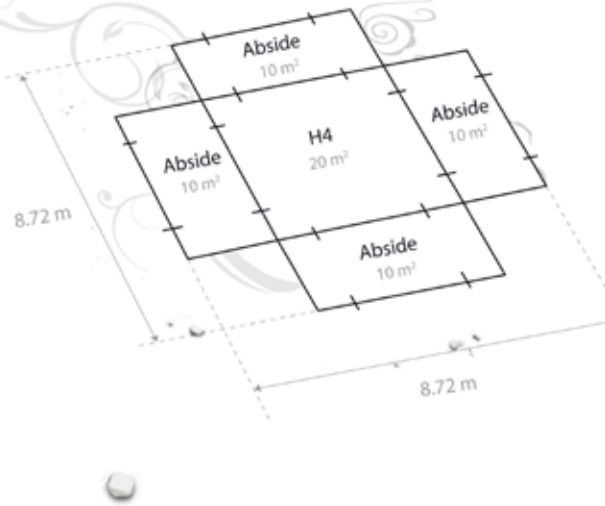
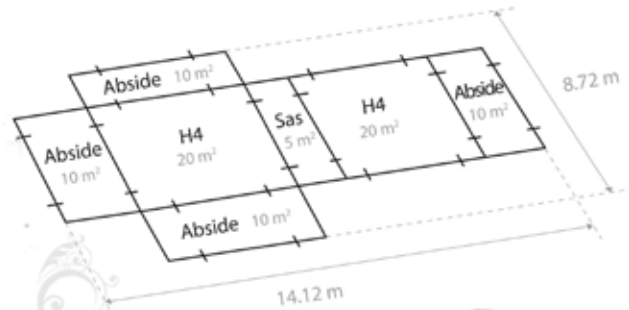
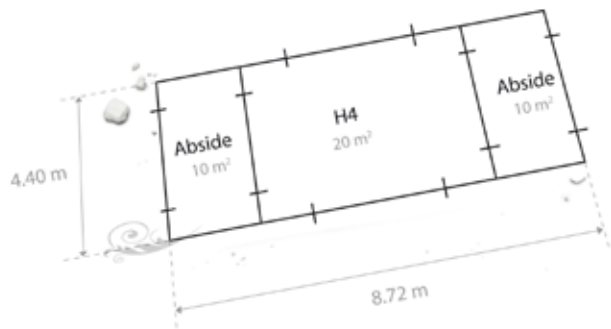
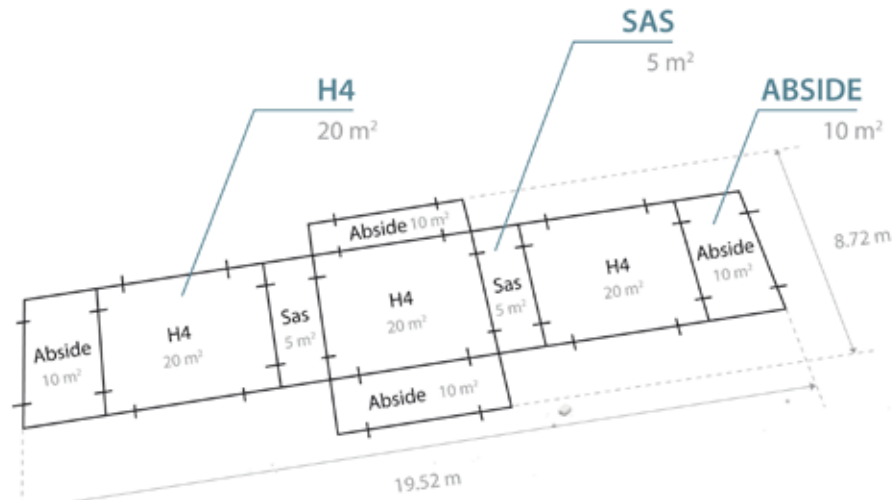

Geolodge offers packages that are easily adapted to suit any need.
Please refer to the following pages for lodge specifications and descriptions of our standard and optional features, which may be assembled according to your preferences.



Components	Standard Lodge	Suite Lodge	Deluxe Suite Lodge	Event Structure	Page
Structure - H4 - 20 m ²	20	40	20	20	6
Structure - H2 - 20 m ²					7
Structure - Abside - 10 m ²					8
Structure - Sas - 5 m ²					9
Fabric					10
Flooring					11
Bathroom					12
Energy					13
Air Treatment					14
Lighting					15
Flooring & furniture					16
Bed					17
Transportation & storage					18
Maintenance					19
	OPTION	OPTION	OPTION	OPTION	20



1

2

4

3



H4 - p. 6



H2 - p. 7



Abside - p. 8



SAS - p. 9

Standard specifications

- Flexible aluminum tube frame
- Sand colored canvas or custom printed inside lining
- International Security standard
- Ground fixation by pickets or ballasting
- Removable doors with screens
- See-through removable doors
- Minimum height : 1.8 m
- Maximum height : 2.6 m
- 3 windows and door kit (standard fabric, insect repellent fabric, translucent fabric)

Structure



H4

- Main room with 4 doors
- Weight : 470 kg
- Floor area : 20m²
- Modular in 4 directions with connection spaces
- 2 hours to build by non-professional staff

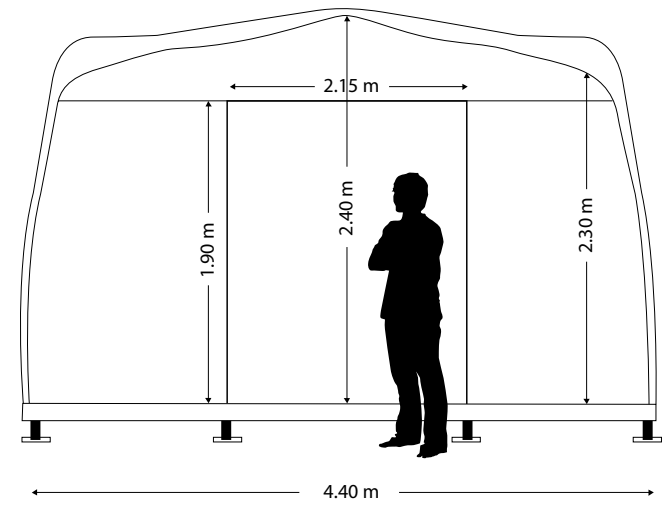
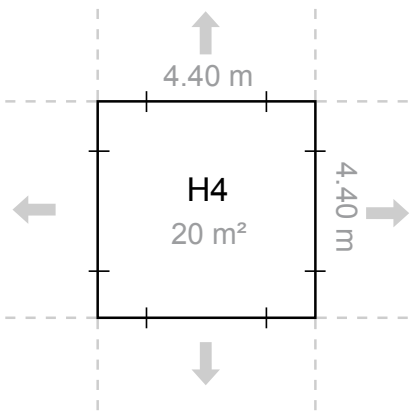

Structure

2

H2

- Main room with 2 doors and 4 side windows
- Weight : 470 kg
- Floor area : 20m²
- Modular in 2 directions with connection spaces
- 2 hours to build by non-professional staff

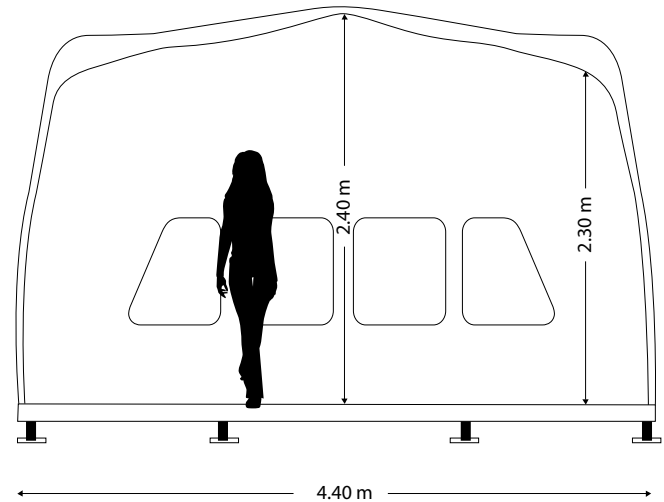
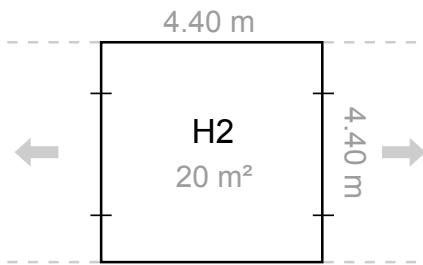
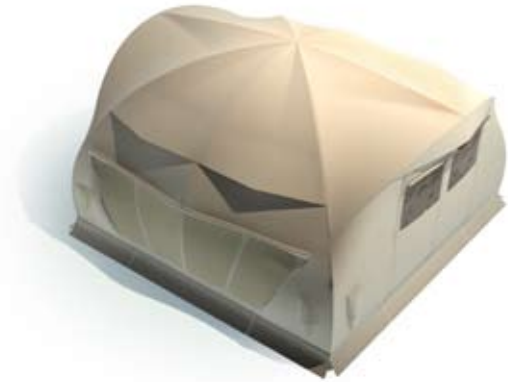

Structure

3

Abside

- Extension room
- Weight : 224 kg
- Floor area : 10m²
- Modular space to connect with a main room
- 1 hour to build by non-professional staff

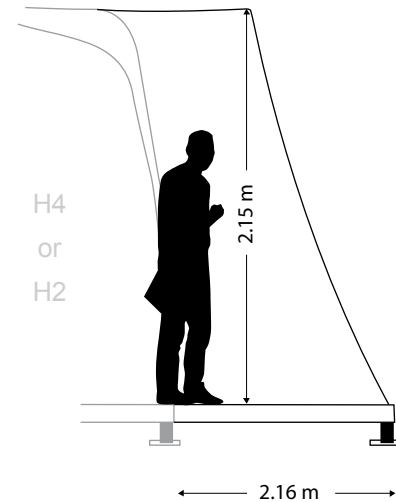
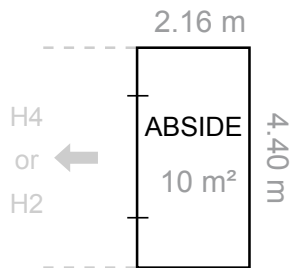

Structure

4

SAS

- Main rooms connection space
- Weight : 100 kg
- Floor area : 10m²
- Modular space to connect two main rooms together
- ½ hour to build by non-professional staff

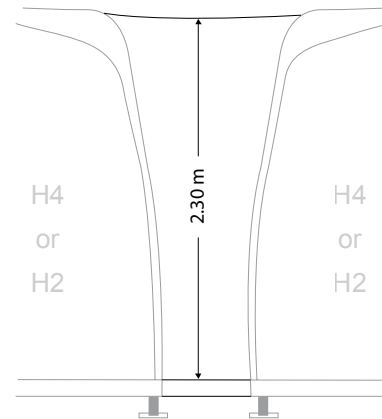
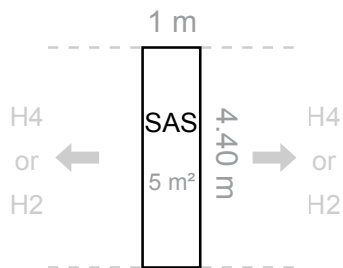



Fabric

Exterior fabric : standard or printed

- Waterproof polyester fabric
- Fire-resistance fabric conform to international standards



Standard color



Specific printed design



Insulated interior fabric

- Provides insulation
- Polyester 3D Mesh

Colors available





Interchangeable and removable doors and windows

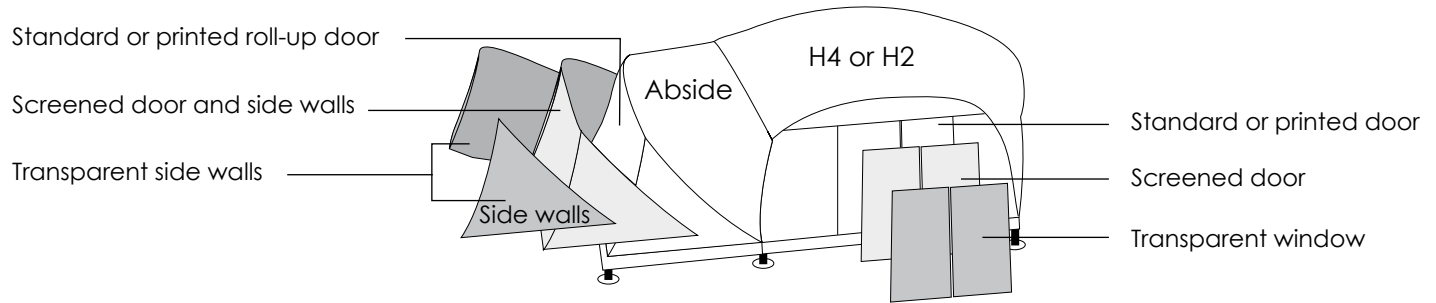

1

Insect shield

- Polyester mesh "one way visibility" for enhanced intimacy
- Polyester mesh treated with Permethrin insecticide

Standard colors



2

Transparent wall

- Polyurethane film clear transparent panel

Transparent window

- Clear Polycarbonate pane



Specifications

- Weight : 17 kg/m²
- Modular with 4 basic elements
- Adaptable to ground slopes up to 20 %
- Honeycomb floor
- Load resistance : 500 kg/m² (International standard)



Optional
Handicapped Access Ramp

Flooring

Extendable basic element

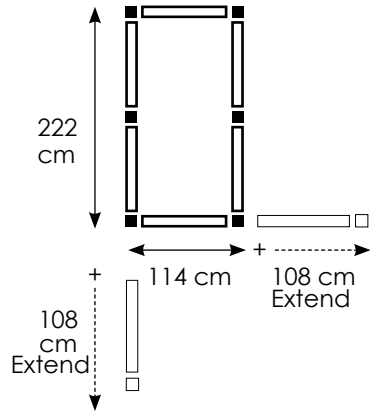

H4 / H2

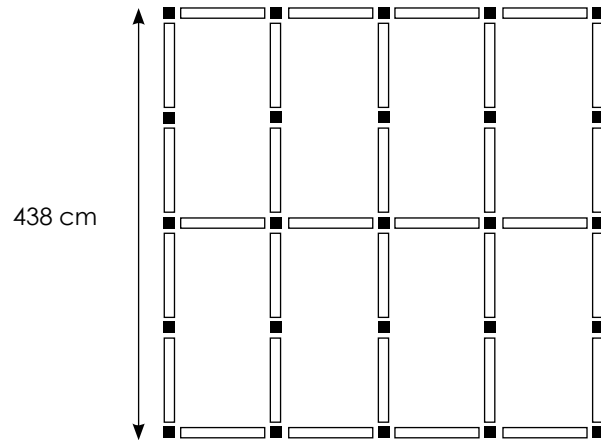

Sas

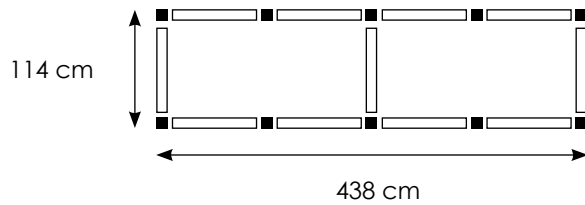

Abside

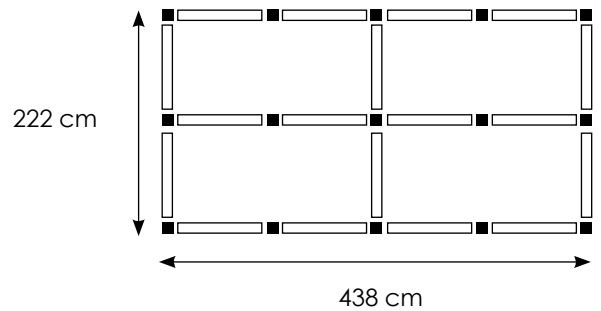



Bathroom



Shower

- Weight : 65 kg
- Size : 2.4x1.3 x 0.9m
- Water treatment system
- 2 integrated LED lights
- Water tank : 30 l
- Autonomy : 30 showers
- Energy : 24VDC
- 2 showerheads
- Remote control for on/off, showerhead switch and water heater



Sink

- 1 integrated LED light
- Must be connected to a shower
- Large mirror
- Size : 1.6 x 0.8 x 0.4 m
- Weight : 16 kg



Toilet

- Weight : 16 kg
- Size : 1 x 0.5 x 0.4 m
- Water tank : 30 l.
- Autonomy : full
- Energy : 24VDC

Optional water heater

- Weight : 12 kg
- Size : 0.36 x 0.21 x 0.66 m
- Fuel : Propane, butane
- Electronic control designed for safety and energy efficiency
- Thermostat-controlled water temperature

Energy & air treatment



Flexible solar panel

- Weight : 1.4 kg
- Size : 1.3 x 0.7 m
- Power : 62 watts ; 24 VDC
- Portable, flexible, supple
- Waterproof

Rigid solar panel

- Weight : 12.84 kg
- Size : 1.16 x 0.76 m
- Power : 120 watts ; 24 VDC

Windmill

- Weight : 6 kg
- 400 watts at 12.5 m/s
- Startup speed 2.7 m/s

Natural gas generator

- Weight : 115 kg
- Size : 0.75 x 0.6 x 0.58 m
- Power : 4800 watts ; 230 VAC
- Fuel : Liquid petrol gas, propane

Fuse and energy control suitcase

- General badge switch
- Wind turbines and solar panels input
- Battery load controls
- Lighting, toilet, sink and shower controls
- Digital screen for monitoring energy consumption
- 220 VAC multi-socket plug

Key card

- General switch controlling the lodge energy system
- Each box is provided with 2 key cards for clients/visitors and 1 master key card for the operator
- Client/visitor key cards only work with a single corresponding Fuse and energy control suitcase
- Master key cards work with every Fuse and energy control suitcase

Optional :

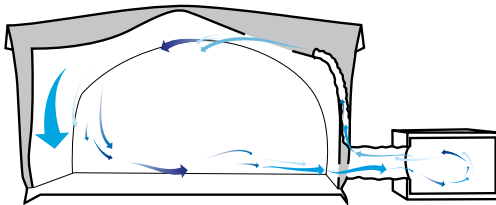

Air conditioning

- Weight : 50 kg
- Powered by natural gas generator
- Air heating and cooling to maintain temperature between 5 and 40 C°
- Monitor and switch control pad inside the tent

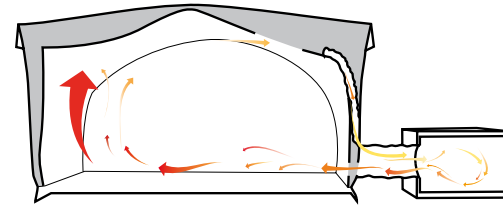

Heating

- Weight : 21 kg
- Powered by propane gas
- Air heating for temperature above - 5 C°



Lighting



White light



Multichrome light



Manual light switch



Multichrome light remote control

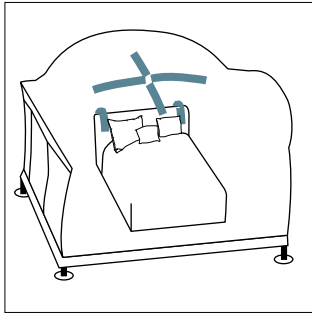

H4

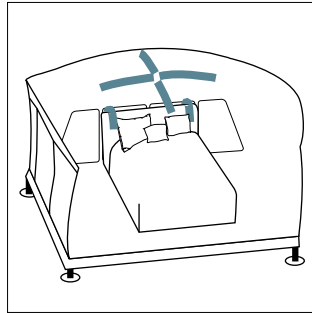

H2

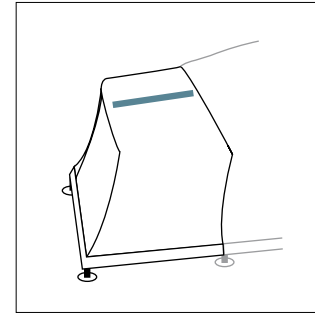

Abside

- 4 white light
- 2 multichrome light
- 3 manual light switch
- 2 multichrome light remote controls

- 1 white light
- 1 manual light switch



Flooring & furniture

1

Flooring & furniture

- Wood from renewable forests
- Modular for every structure
- Required for the bathroom

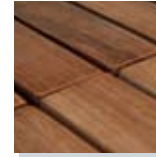

2

Bamboo flooring

- Insulated
- Fixed to the floor
- Modular for every structure



Optional light foldable furniture

- Dinner Table
- Directors chair
- Bedside table
- Long chair
- Small Table
- Chest of drawers
- Cabinet
- Desk



1

2

3

Bed

Double bed, single bed

- Weight : 25 kg
- Aluminum frame with high comfort Bultex brand mattress and headboard
- Single bed size : 200 x 90 x 54 cm
- King size bed with 2 attached single beds : 200 x 180 x 54 cm

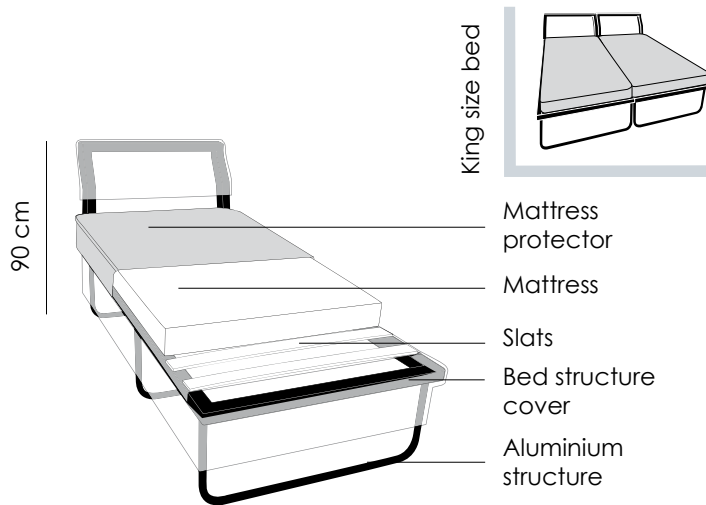

Optional :

①

Linen

- Single bed - comforter (140 x 200 cm)
- Super king comforter (260 x 240 cm)
- Square pillow (65 x 65 cm)
- King size pillow (50 x 90 cm)

②

Pillows

- Square pillow - pillowcase (65 x 65 cm)
- Rectangle pillow - pillowcase (50 x 90 cm)

③

Comforter

- Single bed - comforter (140 x 200 cm)
- Double bed - comforter (260 x 240 cm)



3

1

2

4

Transportation & storage



Universal Bag

- Weight : 3 kg
- Suitable for all equipment
- Easily stackable
- Can be carried easily by hand



Palette

- Weight : 30 kg
- Size 77 x 116 x 114 cm
- Maximum load capacity : 500 kg
- Foldable and stackable
- Protection cover



Container

- Container ISO 20 ft
- 1 container = 30 palettes



Mini forklift truck

- Weight : 550 kg
- Maximum range : 500 kg at 1.6 meter high
- Run on caterpillar, reduce the ground impact
- Diesel engine, 1.5 h / gallon
- 45 min to load a 20 feet container

1



2



3



4



Maintenance

1

Energy maintenance box

- Protects and hides the energy control system
- 1 fuse and control suitcase
- 4 to 6 batteries in 2 or 3 suitcases

2

Water treatment maintenance box

- Protects and hides the water treatment system
- Water heater

3

Standard palette cover

- Polyester fabric
- Waterproof
- Secures the palette content

4

Optional all-weather cover with soundproofing

- Same specifications as the standard palette cover
- Air extraction for the water heater and the A/C and heater
- Sound screen for the generator

Optional air treatment maintenance box

- A/C and natural gas generator with a remote control box
- Or heater

Contact

Etienne Dufour

Geolodge Business Development Director

etienne.dufour@geo-lodge.com

+33 (0) 6 10 90 17 62